



TJB ENTERPRISE

Turning Dreams Into Quality

Multi Head Weigher with high Speed Pouch Packing Machine

Collar Type Multihead Weigher

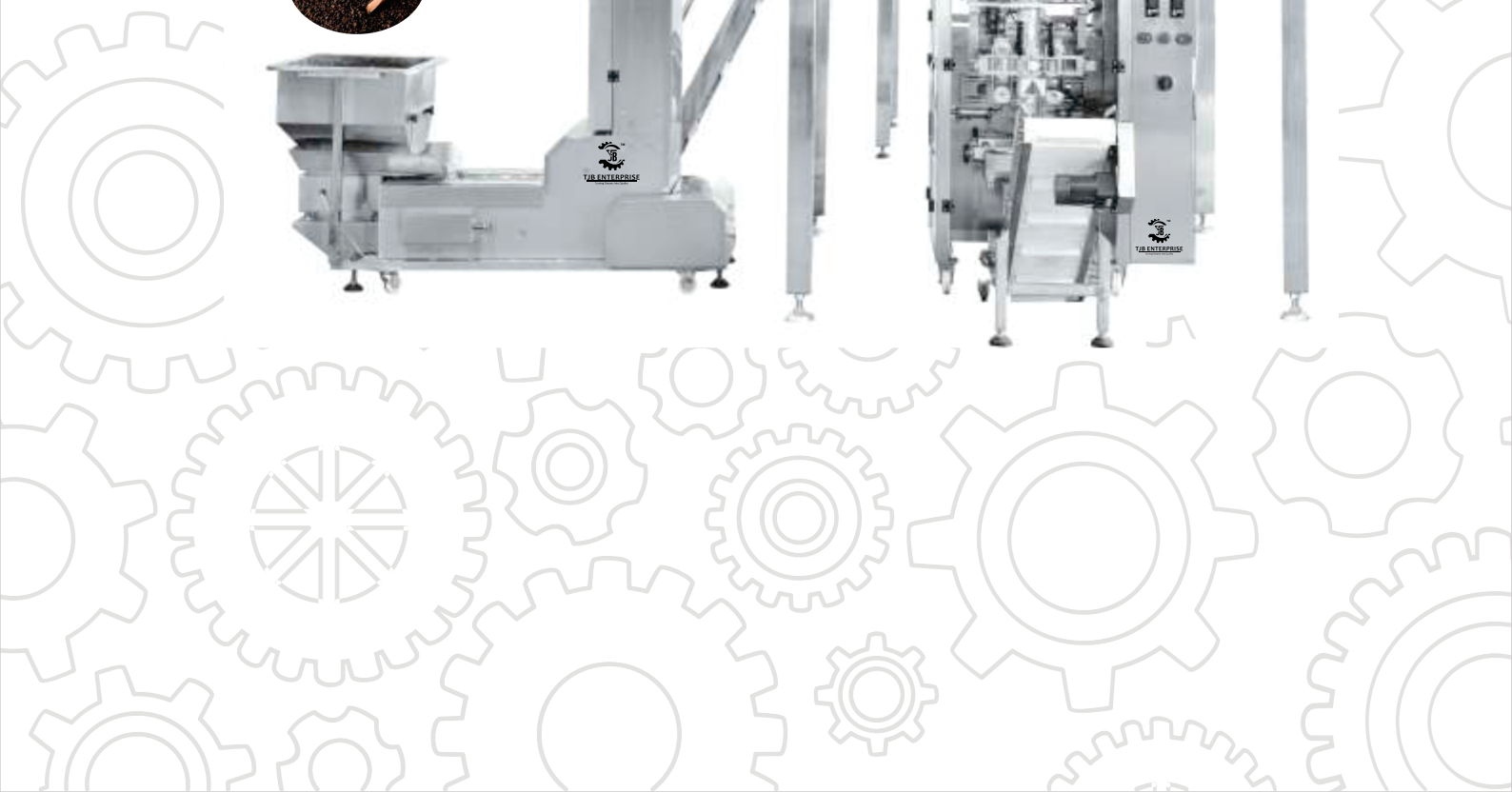



TJB ENTERPRISE

Turning Dreams Into Quality

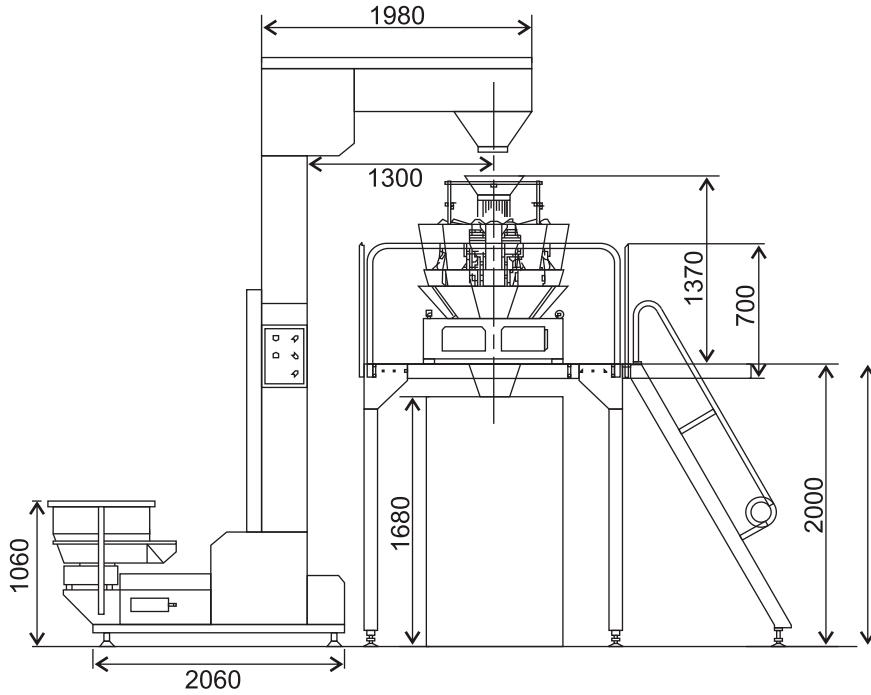

Automatic Form Fill & Seal Machine with Multihead Weigher for **Chips, Fryms, Namkeen, Snacks, Grains & Free Flow Products Like Pulses, Soya Chunks, Whole Spices, Detergent Powder, Pesticides Etc.** in Multihead Weigh Filler

Technical Specification

Packing Range	: 10gm to 1kg
Filling System	: (Multi Head Weigher) 10 Head Weigh Filler & 14 Head Weigh Filler
Filling Accuracy	: -/ + 0.1%
Type of Sealing	: Center Seal
Film Size	: 100mm-500mm width x 100mm-360mm length
Film Roll Type	: Laminated Film in Roll Supported Film E.g. Aluminum Foil Pe
Speed	: 45 to 60 bag/min (Varies with the nature of product & filling range)
Power	: 3kw 230v / AC / Single Phase / 50hz
Wooden Case	: 1300mm x 1000mm x 1000mm (H x W x L)
Machine Size	: 72" x 85" x 126
Weight	: 1400kg (Approx)
Compressed Air	: 6 CFM @ 6 bar
Optional	: Batch Coding Device

